

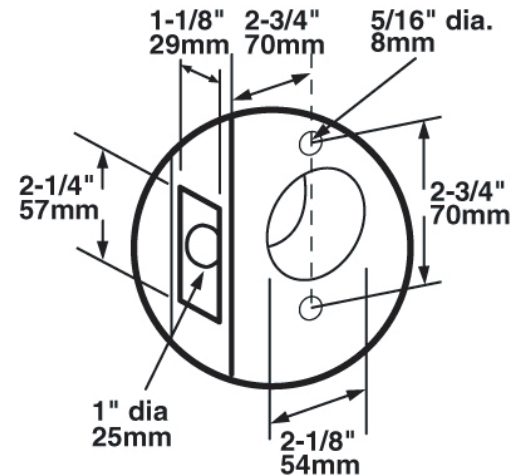

GRADE 1 COMMERCIAL CLUTCH LEVER LOCKSETS

NEW!

- UL / ULC Listed
- ADA Compliant
- For 1 3/8" - 2" thick door
- Through bolt installation
- ANSI strike standard
- CLUTCHED Freewheeling lever
- Stainless Steel Chassis
- 6 pin "C" keyway cylinder standard
- 1/2" throw deadlatch
- 2 3/4" backset (2 3/8" avail.)
- Satin chrome finish
- Non-handed

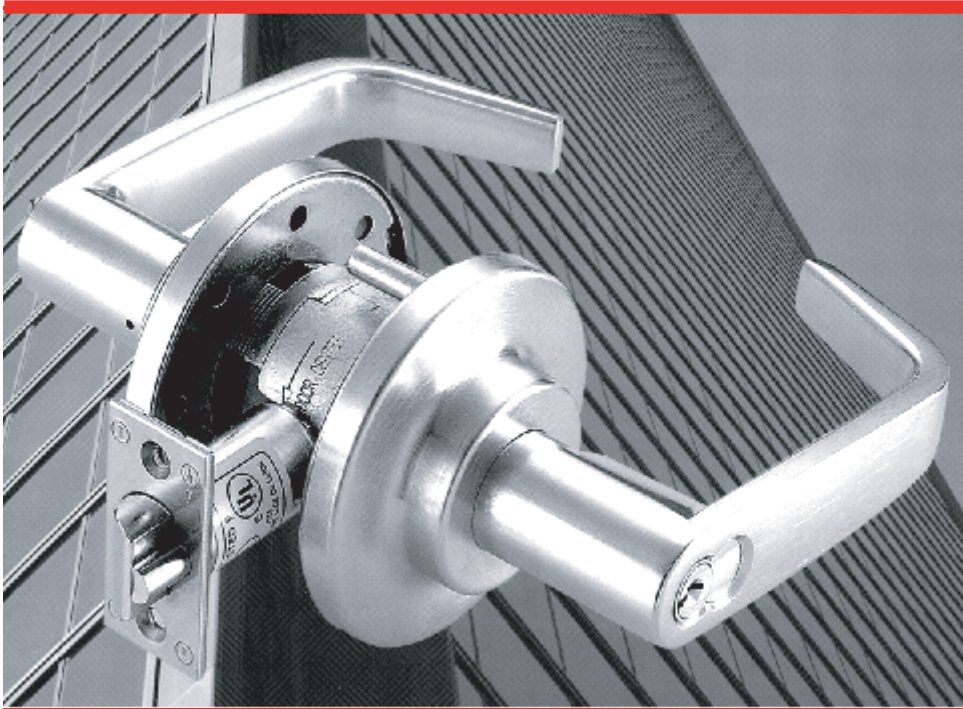

FEATURES

- ➡ Heavy Duty Stainless Steel chassis is standard, allows for versatile applications.
- ➡ Quality cast and machined stainless steel hubs mounted with heavy duty return springs tested over one million cycles.
- ➡ Heavier rose liners material provides more attack resistance.
- ➡ Threaded outside rose assembly adjustable for door thickness without removing keyed lever.

PART NUMBERS

**ENTRANCE
HA-DL53CH-26D-CLUTCH**

**CLASSROOM
HA-DL70CH-26D-CLUTCH**

**STOREROOM
HA-DL80CH-26D-CLUTCH**



1220 Dundas Street East, Toronto Ont. M4M 1S3
TEL: 416-462-1919 / 1-800-268-6741
FAX: 416-462-1922 / 1-800-903-3303
sales@hardwareagencies.com